

# TYPE 400 WITH BONNET

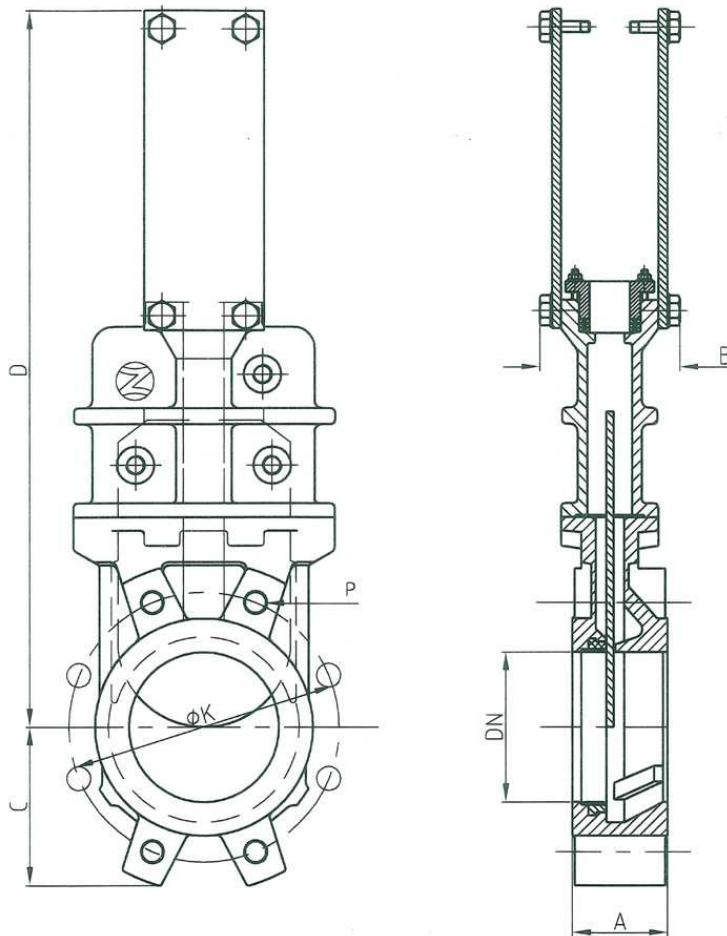

DN	INCHES	A	B	C	D	$\phi K$		P		
						PN 10	ANSI 150	NO.HOLES	PN 10	ANSI 150
50	2"	60	90	60	340	125	120,6	4	M16	W 5/8"
65	2 1/2"	60	90	68		145	139,7	4	M16	W 5/8"
80	3"	64	90	90		160	152,4	8	M16	W 5/8"
100	4"	64	90	105		180	190,5	8	M16	W 5/8"
125	5"	70	100	118		210	215,9	8	M16	W 3/4"
150	6"	76	100	135	568	240	241,3	8	M20	W 3/4"
200	8"	89	120	170	737	295	298,4	8	M20	W 3/4"
250	10"	114	120	202	930	350	361,9	12	M20	W 7/8"
300	12"	114	120	240	1015	400	431,8	12	M20	W 7/8"
350	14"	127	192	255	1175	460	476,2	16	M20	W 1"
400	16"	140	192	295	1310	515	539,7	16	M24	W 1"
450	18"	152	192	318	1465	565	577,8	20	M24	W 1 1/8"
500	20"	152	192	345	1593	620	635	20	M24	W 1 1/8"
600	24"	178	290	405		725	749,3	20	M27	W 1 1/4"

\*Higher diameters under request.